

# MG400

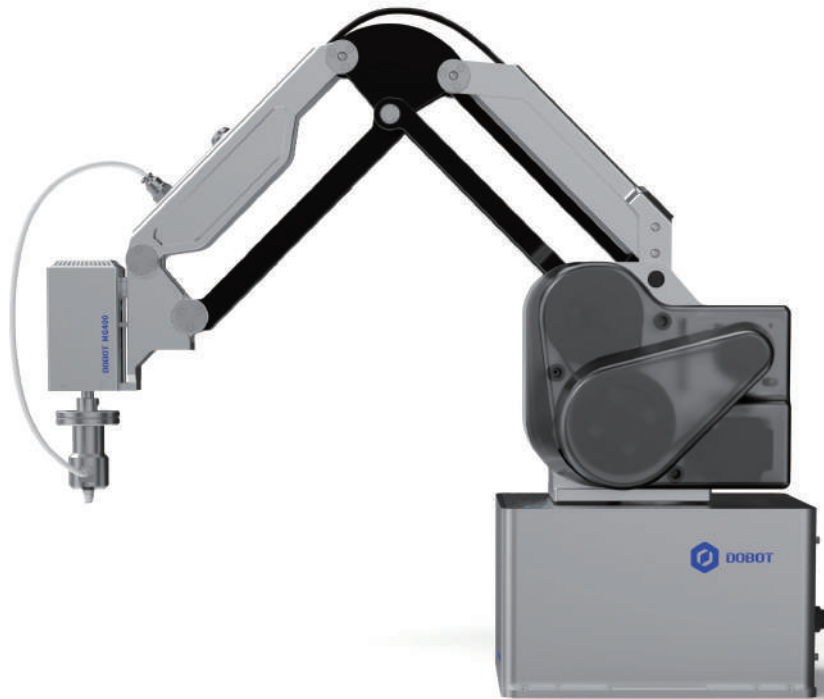

## Scope of Work

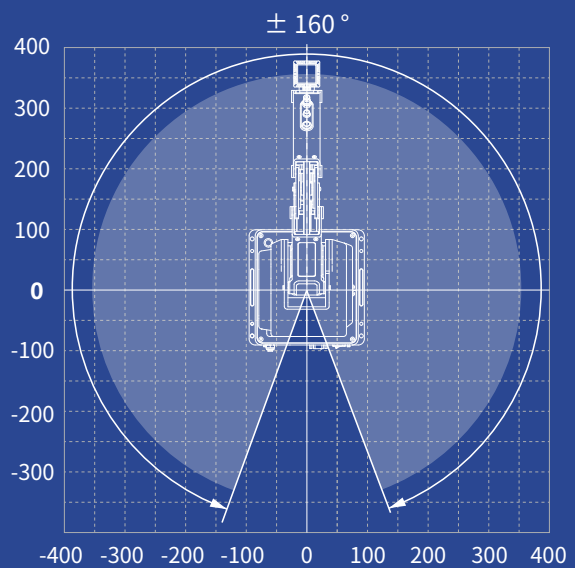
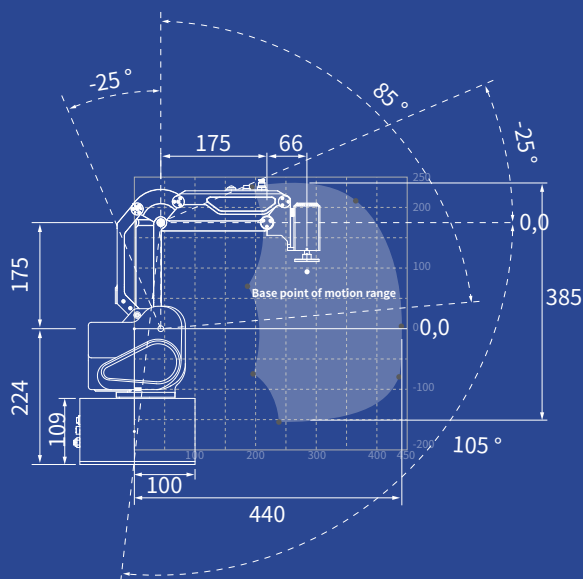

# Specifications

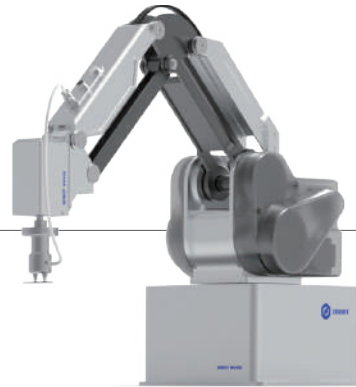

Product Name	MG400	
Product Model	DT-MG400-4R075-01	
Number of robot axes	4	
Payload	500g (Max 750g)	
Reach	440mm	
Repeatability	±0.05mm	
Range of joint motion	J1	±160°
	J2	-25° - 85°
	J3	-25° - 105°
	J4	-360° - 360°
Max. Speed of Joints	J1	300° /s
	J2	300° /s
	J3	300° /s
	J4	300° /s
Power Supply	100-240 V AC, 50/60 Hz	
Rated Voltage	48V	
Rated Power	150W	
Communication	TCP/IP, Modbus TCP	
Installment	Table Installation	
Weight	8kg	
Base Size	190mm × 190mm	
Working Environment	0 °C -40 °C	
Application Software	DobotStudio 2020, SCStudio	

## Base Mounting Holes

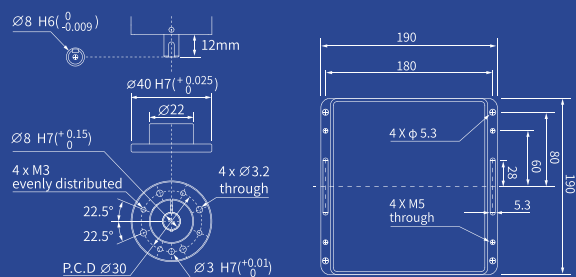

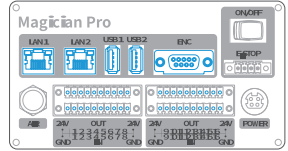
 Interface	Digital Input	16
	Digital Output	16
	Ethernet	2
	USB 2.0	2
	Encoder Input	1

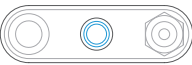
 Terminal Interface	Digital Input	2
	Digital Output	2
	Airway	1