

M1 PRO

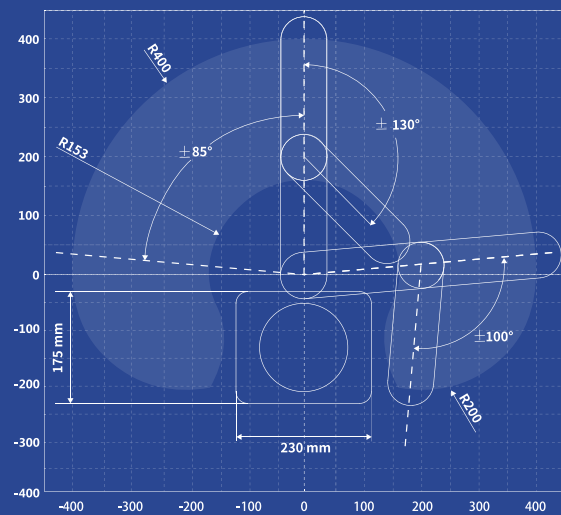

Scope of Work

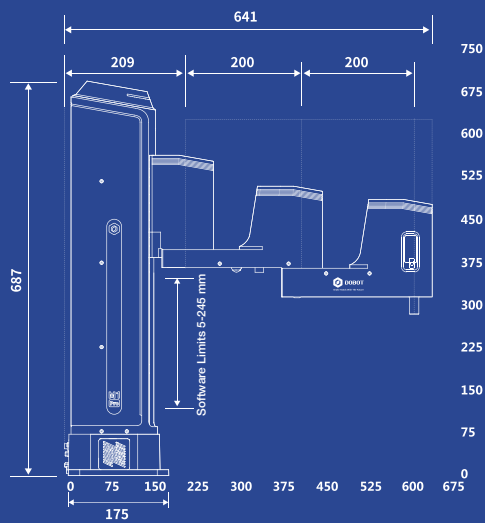

Specifications



Product Name	M1 Pro	
Arm Length	400mm	
Rated Payload	1.5kg	
Max. Range of motion	Classification	Software Limits
	Big arm	-85° -85°
	Small arm	-130° -130°
	Z-axis Greasing Screw Rod	5mm-245mm
Max. motion velocity	End rotation	-360° -360°
	Joint velocity of big and small arms	180° /s
	Resultant velocity of big and small arms	2000mm/s
Repeatability	Z-axis velocity	1000mm/s
	±0.02mm	
Power Supply	100V-240V AC, 50/60Hz	
Communication Interface	Ethernet、Modbus	
I/O	16 Digital Outputs 16-channel digital input	
Control Software	DobotStudio 2020, SCStudio	

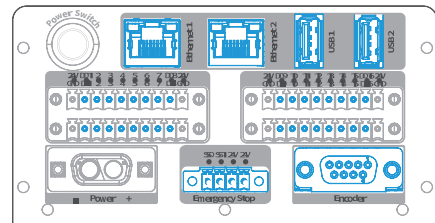
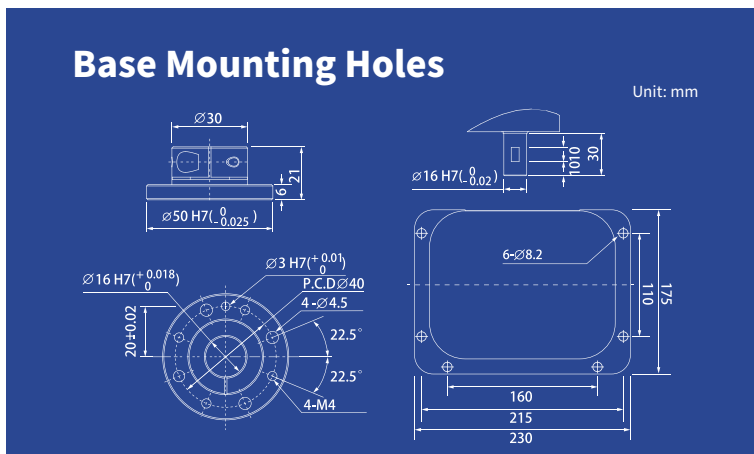

Base Interface		Terminal Interface	
Digital Input	16	Digital Input	4
Digital Output	16	Digital Output	4
Ethernet	2		
USB 2.0	2		
Encoder Input	1		
Emergency Stop Interface	1		